



# **D-Series Automatic Engine Overspeed Shut Down Valves**

**(Bendix Types with integral air cleaners)**

## **Selection, Application and Maintenance**

D45F, D51F, D57F, D64F

## DESCRIPTION

A range of spring loaded poppet valves designed to automatically stop an engine by closing down the air intake should excessive overspeeding occur. Fitted with integral air cleaner.

The closing force on the valve is provided by the intake air flow passing through. As the air flow increases, the closing force builds up. This is resisted by a spring, the pre-load of which is adjustable such that at a given air flow the resulting force overcomes the spring resistance and causes the valve to close. Once closed the valve will not reset to the open condition until the engine stops.

This type of valve may be fitted to either naturally aspirated or turbocharged engines. It should be noted however that for a given valve setting the repeatability of the actual automatic shut down speed has a greater scatter in the case of a turbocharged engine. However, unless for special reasons a precisely repeatable shut down speed is required, adequate protection from excessive overspeed and potential resulting damage is still achieved.

The basic dimensions for this group of valves are tabulated below.

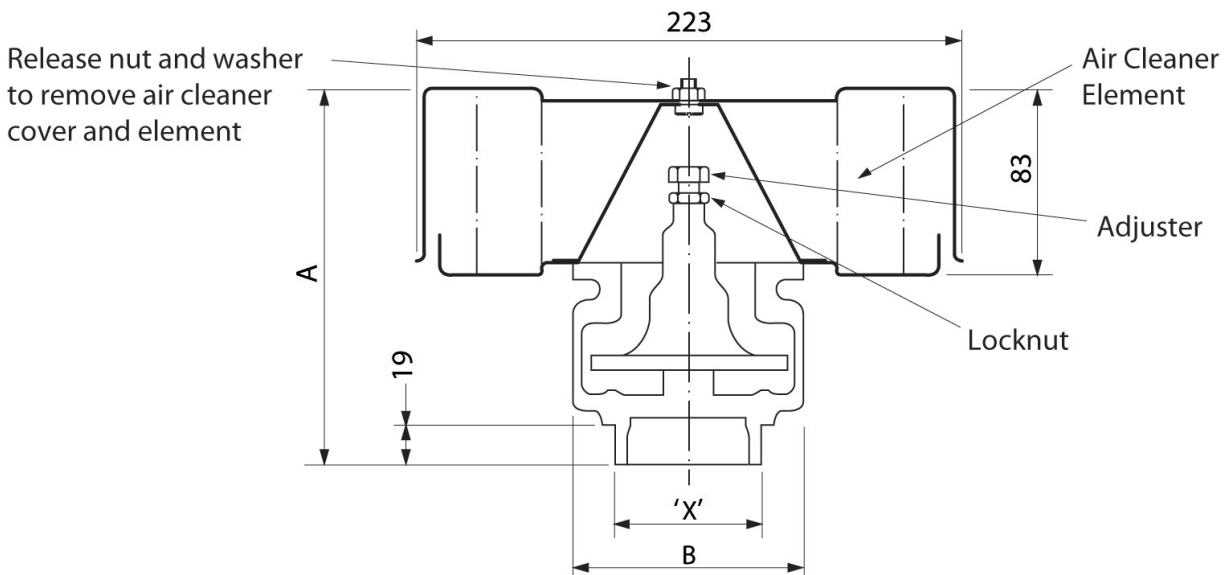

Valve Type	A mm	B mm	Weight (valve only) Kg
D45F	181	86	2.4
D51F	184	94	2.5
D57F	187	104	2.6
D64F	188	114	2.7

Outside diameter 'X' is selected to suit the size of the engine air intake hose - see page 3 "SELECTION"

Note: The air cleaner fitted to this range of valves is designed for light/medium duty applications. It should not be used for heavy duty applications as unacceptable short air cleaner service intervals may result. Further advice is available from the Chalwyn Sales Office.

## SELECTION

Determine the rating of the engine to which the valve is to be fitted. Using the table below identify which valve(s) would be suitable. Finalise the selection by identifying the valve which can also be supplied with end diameters to match the bore of the engine air intake hose at the position the valve is to be fitted.

Note, end diameters are manufactured to the nearest 1mm. Generally, where more than one valve meets all requirements, select the larger valve size to minimise engine air intake restriction.

### Valve Selection chart in Metric Units

Valve Type	Engine Power at rated Speed kW		Engine Air Intake Hose Bore mm	
	Naturally Aspirated Engine	Turbocharged Engine	Minimum	Maximum
D45F	7.5 to 38	7.5 to 32	40	70
D51F	15 to 54	15 to 45	51	80
D57F	22 to 72	22 to 60	57	83
D64F	30 to 93	30 to 78	63	96

### Valve Selection chart in Non-metric Units

Valve Type	Engine Power at rated Speed kW		Engine Air Intake Hose Bore mm	
	Naturally Aspirated Engine	Turbocharged Engine	Minimum	Maximum
D45F	10 to 50	10 to 42	1 9/16	2 3/4
D51F	20 to 72	20 to 60	2	3 1/8
D57F	30 to 97	30 to 80	2 1/4	3 1/4
D64F	40 to 125	40 to 104	2 1/2	3 3/4

**Notes:**

- \* For "Bendix Valves" without air cleaner see Chalwyn publication CE204.
- \* For combined options of fitted air cleaner and manual shut down see publication 207.

## **FITTING**

Remove the existing engine air cleaner. Using a short re-inforced rubber cuff and clips mount the Chalwyn valve. The valve may be mounted with the direction of the air flow anywhere between vertically down and horizontal.

2. The method of attachment of the D valve must give adequate support for the valve and prevent excessive vibration. Use suitable support brackets if necessary.

3. Particular care must be taken to ensure the integrity of the pipework between the Chalwyn valve and engine intake manifold. Ideally metal pipework should be used. Where unavoidable, gaps in the metal pipework should be as short as possible, (taking into account any relative movement) and connected by re-inforced rubber hose. The possibility of hose collapse on closure of the valve should be avoided.

4. Any engine crankcase breather connections into the engine air intake system, or any internal breather connections to the engine air intake ports, must be sealed and replaced by an external breather system venting to atmosphere. (External breather system kits for various engine types are available from Chalwyn.)

5. Where more than one Chalwyn valve is fitted to an engine, as in the case of an engine with multiple intake pipes, a balance pipe arrangement must be fitted to link the various intake pipes together downstream of the shut down valves. Typically the diameter of the balance pipe should be about 30% of the individual intake pipes.

## ADJUSTMENT

Once the Chalwyn valve is installed, adjustment of the overspeed trip setting is carried out using the inlet adjuster and locknut (refer to diagram). Basically rotating the inlet adjuster clockwise will increase the engine speed at which automatic shut down occurs.

As supplied, the valve will be adjusted such that shut down will generally occur well below the engine high idle speed. To increase the shut down speed to the required setting proceed as follows:-

Once the Chalwyn valve is installed, adjustment of the overspeed trip setting is carried out using the adjuster and locknut (refer to diagram). Basically rotating the adjuster clockwise will increase the engine speed at which automatic shut down occurs.

As supplied, the valve will be adjusted such that shut down will generally occur well below the engine high idle speed. To increase the speed at which automatic shut down occurs, proceed as follows:

1. Start engine. Slowly accelerate. Note speed at which shut down occurs.
2. Remove the air cleaner cover and element to expose the adjuster and locknut (see diagram).
3. Release locknut. Turn adjuster clockwise one turn. Tighten locknut.
4. Refit air cleaner cover and element.

5. Start engine. Slowly accelerate. Note speed at which shut down occurs.

6. Repeat steps '2' to '5' until the first setting at which the engine does not shut down at high idle speed (i.e. maximum throttle, no load).

Then either:

a) Use the results of shut down speed versus adjuster setting as a calibration check to make a final adjustment to give the required setting (typically 10% to 15% over high idle).

or

b) If a very precise setting is not required, turn the adjuster a further one turn clockwise to take the shut down above high idle speed by a suitable margin. When using this setting procedure it may be found that the engine occasionally shuts down during the normal operation. If so, turn the adjuster clockwise by a further one half turn.

7. Ensure the adjuster locknut is fully tightened. (Use a thread lock adhesive on the locknut threads).

### Notes:

#### Turbocharged Engines

When setting up a valve on a turbocharged engine using the preceding method, it may be found that at high power outputs, the engine will shut down at a lower speed than required. If this occurs, further small adjustments in steps of one half turn clockwise should be made until the problem is eliminated.

#### Jammed Valve

If in the course of adjusting the valve it jams on its seat, release by turning CLOCKWISE viewed from adjuster end.

## MAINTENANCE

The recommended routine maintenance period is three months. This period is dependent on the operating conditions of the engine and, by experience, may need to be varied.

### **Three Monthly:**

1. Disconnect intake pipework and release the valve from any support brackets etc. to allow it to be removed.
2. Inspect the valve internally for cleanliness. If necessary clean in paraffin or white spirit taking normal precautions. Dry the valve thoroughly.
3. Check there is no excessive wear and that the valve moves smoothly over its complete operating stroke. **DO NOT LUBRICATE.**
4. Refit valve. Check valve setting based on the "Adjustment" instructions given herein.

### **Air Cleaner Element**

Replace air cleaner element at the periods recommended by the engine manufacturer. (Spare elements are available from Chalwyn.)

#### **Important Notes:**

The three monthly routine maintenance period requirement is dependent on the operating conditions to which the equipment is exposed and, by experience, may need to be varied.

Any maintenance problems not covered by the routine maintenance schedule should be discussed with your Chalwyn Distributor before any repair work is undertaken.





## **Chalwyn by AMOT**

sales@chalwyn.co.uk

www.chalwyn.com

A division of Roper Industries Limited

### **UK**

Western Way

Bury St Edmunds

Suffolk, IP33 3SZ

Tel: +44 (0)1284 715739

Fax: +44 (0)1284 715747

### **USA**

8824 Fallbrook Drive

Houston

TX 77064

Tel: +1 281 940 1800

Fax: +1 713 559 9419

### **Canada**

3230 97 Street

Edmonton

Alberta, T6N 1K4

Tel: +1 780 465 4429

Fax: +1 780 469 6275

