

CHALWYN

**Coolant Temperature Valves
(Mechanical)**

INSTALLATION, OPERATION & MAINTENANCE

Valve Number

TSZ-100 TSZ-212

DESCRIPTION

Non-electrical temperature valves manufactured in corrosion resistant materials and designed to monitor the temperature of the coolant in a diesel engine. These valves are suitable for zone 1 hazardous area applications and are intended for incorporation into diesel engine oil pressure (or air pressure) operated shut down control systems. Operation is by the valve tripping to vent control system pressure once the preset temperature is exceeded. Details and overall dimensions are given below.

Value Type	Nominal Trip Setting	Dimensions (mm)				Thread		
		a	b	c	d	e	f	g
TSZ-100	100° C	105	25	29	34	1/2bspt	1/4bsp	1/4bsp
TSZ-212	212° F	105	25	29	34	1/2npt	1/4npvc	1/4npvc

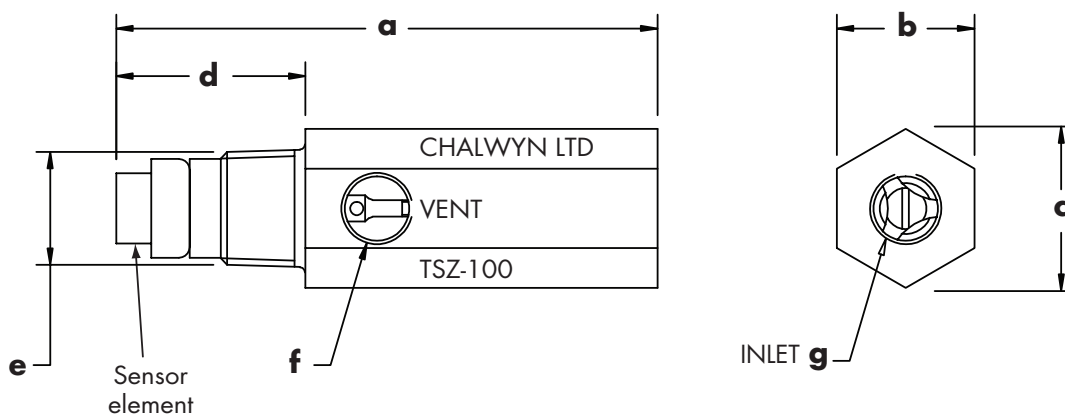

APPLICATION

Used in conjunction with a flow restrictor and a fuel shut down valve* or an intake air shut down valve*, this product provides a simple high coolant temperature engine automatic shut down system. Alternatively it can be combined with a number of other Chalwyn components to engineer a more complex shut down system also including for example high exhaust temperature, engine over-speed and low engine oil pressure.

Notes:

- A.** The fuel shut down valve* and/or air intake shut down valve* to be set at a trip pressure within the range 10 psi (0.7 bar) to 30 psi (2 bar).
- B.** The maximum oil or air pressure applied to the ports of the valve not to exceed 120 psi (8.25 bar).

INSTALLATION

Fit the valve into the hottest part of the engine cooling system. In the cylinder head immediately before the thermostat is recommended. Ensure that the sensor element of the valve will be fully immersed in the engine coolant at all times whilst the engine is operational.

Use suitably rated tube of between 6 and 8 mm. bore to connect the valve into the oil [or air] pressure operated engine shut down control system. A suitable flow restrictor must be fitted into the pressure feed line to the valve. For a typical oil pressure operated system Chalwyn flow restrictor ORZ-060 (or ORZ-061) is recommended. To increase system sensitivity restrictors ORZ-040 or ORZ-041 are available. For complex air operated systems a variable restrictor allowing a degree of system "tuning" may be necessary.

For engine oil pressure operated systems the "vent" port of the valve must be connected to a position on the engine to allow any vented oil to freely drain back into the engine. A connection into the rocker cover would be an example of one suitable arrangement. For air systems the "vent" may be released as appropriate to atmospheric pressure.

It is VERY IMPORTANT that the various components in the shut down control system are correctly sequenced. The pressure supply must initially be fed through the flow restrictor. The pressure line must then be taken to each valve in turn. The recommended method of connection is via a "T" fitting mounted directly onto the valve. The pressure feed is then finally piped to the engine shut down valve(s). All pipe-work in the control system should generally be kept as short and direct as possible but must comply with the sequence outlined above. A typical circuit example is shown below.

The valve is factory set to trip within $\pm 1^\circ\text{C}$ of the nominal temperature. It should be noted however that variations in installation detail, including the trip pressure of the associated shut down valve, may give rise to small variation in the actual shut down temperature. Once installed, and prior to putting the system into service, a check should be carried out as given under "**MAINTENANCE - Monthly**". Where a high degree of accuracy in the shut down temperature is required, the check listed under "**MAINTENANCE - Yearly**" should also be completed. If there is an unacceptable delay in shut down, the sensitivity can be adjusted by fitting a smaller flow restrictor into the system. Additionally it is possible to make small adjustments to the Chalwyn temperature valve (see Page 4).

EXAMPLE OF TYPICAL INSTALLATION

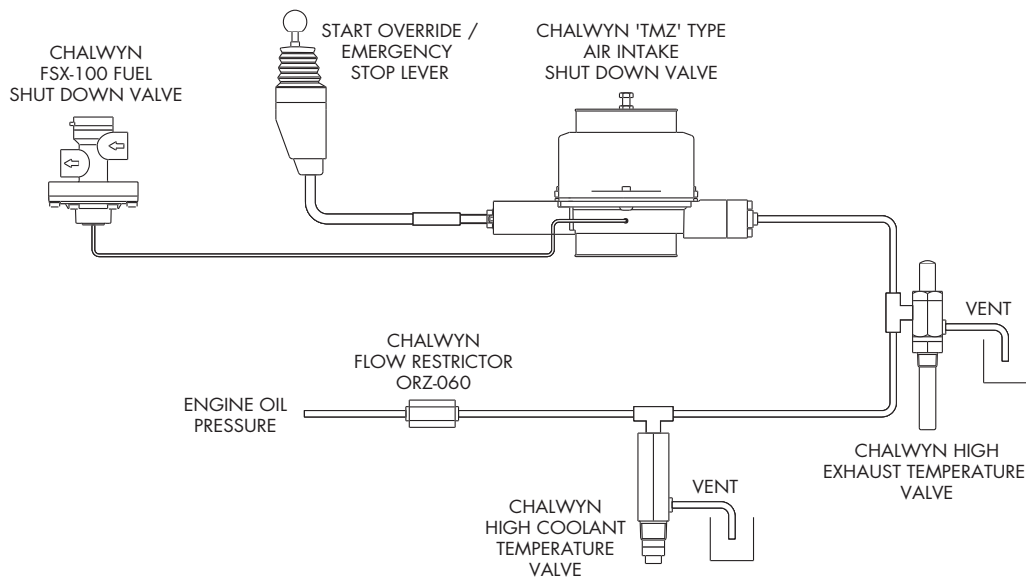

OPERATION

If installed into a control circuit that includes automatic shut down on low engine oil pressure, a special engine start procedure is necessary. For further details see the Chalwyn technical publication supplied with the relevant Chalwyn intake air or fuel shut down valve.

ADJUSTMENT

This valve type is only suitable for trip temperature settings between 97°C (207°F) and 101°C (214°F). Outside these limits correct operation may not be achieved. Before attempting any adjustment, start engine and break the vent line from the installed valve. At an engine coolant temperature of a degree or so below the required shut down temperature, a small amount of oil should start to drip from the vent. This should increase to a steady flow at the required trip temperature. This indicates that the valve is either adjusted correctly or at most requires only minimal adjustment. In this case before adjustment check the circuit is correctly piped up, a suitable sized restrictor is installed and the controlled engine shut down valve is set to a trip pressure of 0.7 bar (10psi) or greater. If this fails to resolve the problem adjust the valve as follows.

Insert a suitable rod or Allen key via the vent port into the 2.5 mm diameter hole as shown below to prevent the push rod turning. With a screwdriver, adjust the setting as shown. Clockwise rotation increases the temperature setting, counter clockwise reduces the setting. The maximum permitted adjustment from the initial setting is 2 turns clockwise or counter clockwise. Do not attempt to adjust the trip temperature outside the range 97°C to 101°C (207°F to 214°F).

Note, if the 2.5 mm diameter hole into the push rod is not visible in the vent port, use a screwdriver to slowly rotate the adjuster until the hole is accessible.

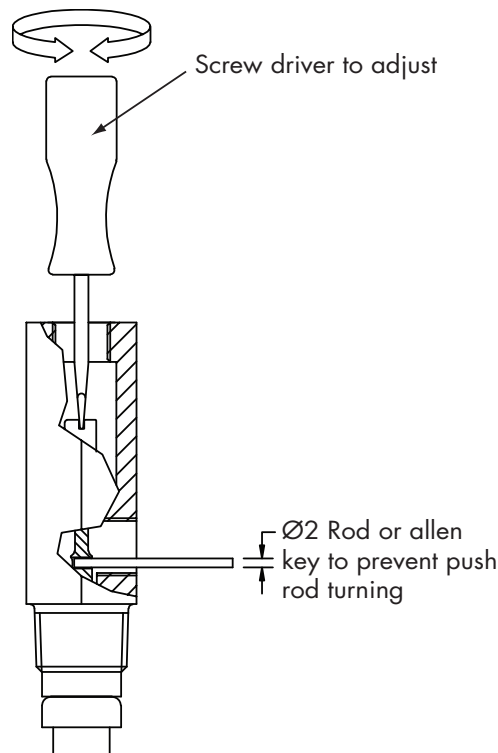

MAINTENANCE

Monthly:

Check for and rectify any leakage.

With the engine running at low to medium speed, crack open the control system pipework at the TSZ valve sufficiently to vent the control circuit pressure. Ensure this results in a rapid automatic shut down of the engine. Where applicable take the necessary precautions to avoid spillage of hot engine oil.

Yearly:

With the control circuit fully piped up and operational and the engine running at low to medium speed, artificially increase the cooling circuit temperature [using a radiator blind or otherwise] to the automatic shut down temperature. Check that automatic shut down occurs at the required temperature. A temperature sensor of known accuracy installed adjacent to the Chalwyn temperature valve should be used for the test. (Alternatively this check may be carried out by testing the valve, fully piped into the control circuit, using an agitated heated water/glycol calibration bath).

IMPORTANT NOTE: Extreme care is required when working on an operating engine. These checks must only be carried out under the supervision of properly qualified and experienced staff and all the necessary safety precautions taken.

CHALWYN LIMITED

Chalwyn Industrial Estate, Parkstone, Poole, Dorset BH12 4PF ENGLAND
Tel: +44(0)1202 715200 Fax: +44(0)1202 715600
www.chalwyn.co.uk

