

SVX-Series Solenoid Actuated Diesel Engine Air Shut Down Valves

(Energised to run types for non-hazardous areas)

Installation, Operation and Maintenance

Special Valves

SVX-304 SVX-309 SVX-504 SVX-509

These valves are special versions of valves SVX-302, SVX-303, SVX-502 and SVX-503 respectively. The general installation instructions given for SVX-302, SVX-303, SVX-502 and SVX-503 are applicable.

Note: The brown cable is positive and the blue cable negative.

Valve Numbers

SVX-300	to	SVX-303
SVX-305	to	SVX-308
SVX-500	to	SVX-503
SVX-505	to	SVX-508
SVX-800	to	SVX-803
SVX-805	to	SVX-808

DESCRIPTION

A range of 12 and 24 volt dc solenoid operated diesel engine air intake closure valves based on the standard Chalwyn slimfit 3", 5" and 8" butterfly valves. These products are available in basic flange mounted form but can also be supplied fitted with hose adaptors.

These valves are designed to fail safe in that if electrical power is lost for any reason, the valve will

always revert to the closed condition.

All valves in this range are also available with fitted internal microswitch to enable status indication.

Typical Valve Arrangement for Types

SVX-300	SVX-301
SVX-307	SVX-308
SVX-500	SVX-501
SVX-507	SVX-508
SVX-800	SVX-801
SVX-807	SVX-808

Important Note: The above listed valve types all require an external timer circuit to switch from "pull" to "hold" coils. - See Page 5.

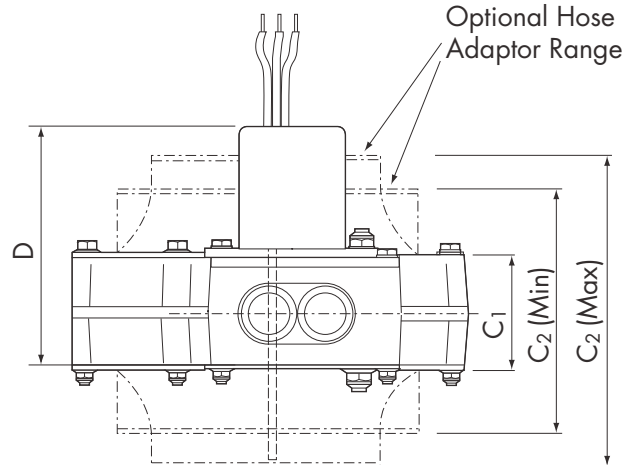
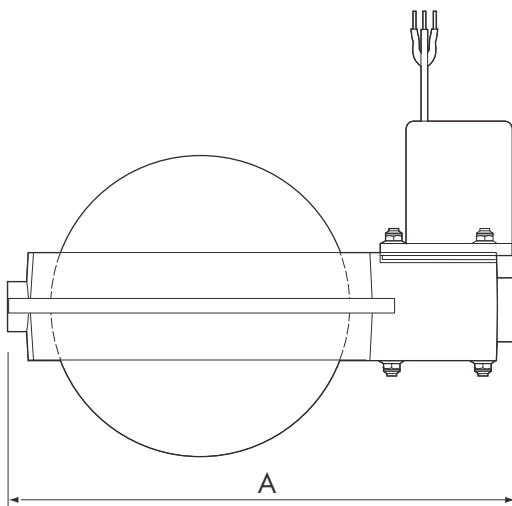
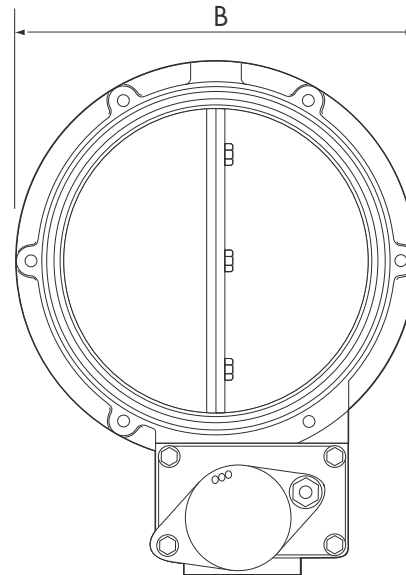

Main Dimensions (mm) and Features

Valve Type		Voltage	Nominal Bore Dia.	A	B	C ₁	C ₂ (min & max)	D
Without Microswitch	With Microswitch							
SVX-300	SVX-308	12	76 (3")	161.0	111.5	37.5	82.5 to 112.5	95.5
SVX-301	SVX-307	24	76 (3")	161.0	111.5	37.5	82.5 to 112.5	95.5
SVX-500	SVX-508	12	127 (5")	217.0	167.5	45.5	102 to 157.5	99.5
SVX-501	SVX-507	24	127 (5")	217.0	167.5	45.5	102 to 157.5	99.5
SVX-800	SVX-808	12	203 (8")	317.5	257.0	56.0	136.5 to 185.5	104.5
SVX-801	SVX-807	24	203 (8")	317.5	257.0	56.0	136.5 to 185.5	104.5

Typical Valve Arrangement for Types

SVX-302	SVX-303
SVX-305	SVX-306
SVX-502	SVX-503
SVX-505	SVX-506
SVX-802	SVX-803
SVX-805	SVX-806

Important Note: The above listed valves are internally switched types and **DO NOT** require an external timer circuit to switch from “pull” to “hold” coils.

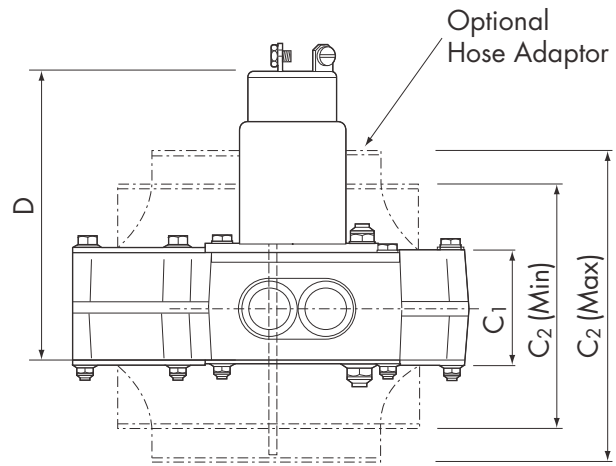
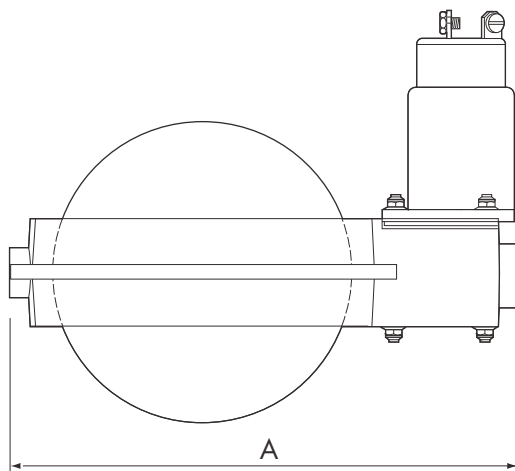
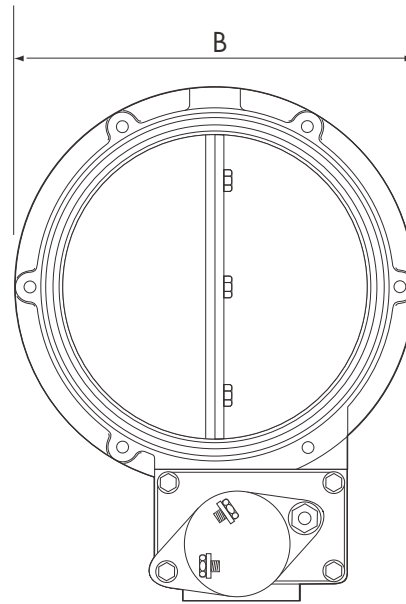

Main Dimensions (mm) and Features

Valve Type		Voltage	Nominal Bore Dia.	A	B	C ₁	C ₂ (min & max)	D
Without Microswitch	With Microswitch							
SVX-302	SVX-306	12	76 (3")	161.0	111.5	37.5	82.5 to 112.5	118
SVX-303	SVX-305	24	76 (3")	161.0	111.5	37.5	82.5 to 112.5	118
SVX-502	SVX-506	12	127 (5")	217.0	167.5	45.5	102 to 157.5	122
SVX-503	SVX-505	24	127 (5")	217.0	167.5	45.5	102 to 157.5	122
SVX-802	SVX-806	12	203 (8")	317.5	257.0	56.0	136.5 to 185.5	127
SVX-803	SVX-805	24	203 (8")	317.5	257.0	56.0	136.5 to 185.5	127

Notes:

Maximum temperature of the engine intake air at the SVX valve not to exceed 150°C.
(See also “Installation” (Mechanical) - page 5)

For equivalent SVX valves for hazardous area applications - see Chalwyn Brochure CE239.

SELECTION

Determine the size and position of the SVX valve to be installed. Within the various constraints imposed by the application, the valve should be as generously sized as possible. Check that the valve can be installed such that the electrical cable can be routed away without risk of damage.

Determine voltage of valve required and whether a two wire (internally switched) or three wire solenoid is required with external switching operated by a customer supplied timer circuit. If a valve status indicator is required, select a valve with an internal micro switch.

Chalwyn 'X' valves are designed for flange mounting. Alternatively these valves can be supplied with fitted hose adaptors selected from the table below.

Hose Adaptor Options

76mm (3") Bore Valves	
Adaptor Part Number	To Suit Hose Bore mm (inches)
HAX-320	38 (1½)
HAX-322	44.5 (1¾)
HAX-301	51 (2)
HAX-302	54 (2 ⅛)
HAX-303	57 (2 ¼)
HAX-304	60 (2 ⅜)
HAX-305	63.5 (2 ½)
HAX-306	67 (2 ⅝)
HAX-307	70 (2 ¾)
HAX-308	73 (2 ⅞)
HAX-309	76 (3)
HAX-312	82.5 (3¼)
HAX-314	89 (3 ½)
HAX-319	102 (4)

127mm (5") Bore Valves	
Adaptor Part Number	To Suit Hose Bore mm (inches)
HAX-501	89 (3 ½)
HAX-502	92 (3 ⅝)
HAX-503	95 (3 ¾)
HAX-504	98 (3 ⅞)
HAX-505	102 (4)
HAX-506	105 (4 ⅛)
HAX-507	108 (4 ¼)
HAX-508	111 (4 ⅜)
HAX-509	114 (4 ½)
HAX-510	117.5 (4 ⅝)
HAX-511	121 (4 ¾)
HAX-512	124 (4 ⅞)
HAX-513	127 (5)
HAX-518	140 (5 ½)
HAX-523	152 (6)

203mm (8") Bore Valves	
Adaptor Part Number	To Suit Hose Bore mm (inches)
HAX-807	178 (7)
HAX-808	203 (8)

INSTALLATION (MECHANICAL)

1. In the case of a naturally aspirated engine, the Chalwyn SVX shut down valve should generally be fitted as close to the engine air intake manifold as possible. If an air intake flame trap is also fitted, the SVX valve must be installed upstream (air cleaner side) of the flame trap.
2. To avoid excessively high intake air temperature at the SVX valve when fitted to a turbocharged engine, it may be necessary to fit the valve either upstream of the turbocharger or downstream of the intercooler (if fitted). Again, if an air intake flametrap is also fitted, the valve must be installed upstream of the flametrap.
3. Where more than one SVX valve is installed on an engine, as in the case of an engine with multiple intake pipes, the shut down valve control system must be arranged to ensure all valves close simultaneously.
4. This valve may be installed either horizontally or vertically.
5. If hose adaptors are used, the mating hose should be of a reinforced type, provide adequate support for the valve and prevent excessive vibration. If necessary, additional support brackets mounted from the engine should be considered.
6. Particular care must be taken to ensure the integrity of the intake pipework between the Chalwyn valve and intake manifold. Ideally metal pipework should be used and any gaps kept as short as possible, (taking into account any relative movement) and closed by reinforced hose.
7. Any engine crankcase breather connections into the intake system between the SVX valve and engine, or any internal crankcase breather arrangement venting directly into the engine intake ports must be sealed and replaced by an external breather system venting either to atmosphere or to the intake system upstream of the shut down valve. External breather system kits for various engine types are available from Chalwyn.

INSTALLATION (ELECTRICAL)

Valve Types SVX-300, SVX-301, SVX-307, SVX-308
SVX-500, SVX-501, SVX-507, SVX-508
SVX-800, SVX-801, SVX-807, SVX-808

The solenoids fitted to these non-hazardous area shut down valves are three wire (external switching) types.

A timer device must be fitted in the solenoid supply circuit to rapidly switch from "pull" to "hold" connections after powering the solenoid (typically less than 1 second).

The control circuit for these devices must also incorporate an overload protection device and the supply cables must not exceed the following maximum lengths.

2.5mm² wire gauge : 2.7m (12 volt types) or 10m (24 volt types).

4.0mm² wire gauge : 4.2m (12 volt types) or 16m (24 volt types).

Supply voltage: 12 vdc (SVX-300, SVX-308, SVX-500, SVX-508, SVX-800, SVX-808)
24 vdc (SVX-301, SVX-307, SVX-501, SVX-507, SVX-801, SVX-807)

Pull current at 23°C : 46 amps (12 volt types) or 25 amps (24 volt types).

Hold current at 23°C : 1.1 amps (12 volt types) or 0.5 amps (24 volt types).

Pull coil: Must not be powered for more than three 30 second periods with 2 minutes to cool between each period. The solenoid must be allowed to cool to ambient before further energising of the pull coil.

The black wire is the common return and must be connected to the negative terminal of the supply.

The white wire is the pull coil supply.

The red wire is the hold coil supply.

For models with an internal microswitch, the microswitch connections are made as follows:

Brown : Supply - common.

Blue : Makes circuit when valve is open

Black : Makes circuit when valve is closed. (Was yellow/green on early models).

Maximum rating of microswitch at 12 or 24 volts = 2 amp.

Valve Types **SVX-302, SVX-303, SVX-305, SVX-306**
 SVX-502, SVX-503, SVX-505, SVX-506
 SVX-802, SVX-803, SVX-805, SVX-806

The solenoids fitted to these non-hazardous area shut down valves are two wire (internal switching) types. The control circuit for these devices must incorporate an overload protection device and the supply cables must not exceed the following maximum lengths.

2.5mm² wire gauge : 2.7m (12 volt types) or 10m (24 volt types).

4.0mm² wire gauge : 4.2m (12 volt types) or 16m (24 volt types).

Supply voltage: 12 vdc (SVX-302, SVX-306, SVX-502, SVX-506, SVX-802, SVX-806)
 24 vdc (SVX-303, SVX-305, SVX-503, SVX-505, SVX-803, SVX-805)

Pull current at 23°C : 46 amps (12 volt types) or 25 amps (24 volt types).

Hold current at 23°C : 1.1 amps (12 volt types) or 0.5 amps (24 volt types).

For models with an internal microswitch, the microswitch connections are made as follows:

Brown : Neutral

Blue : Makes circuit when valve is open

Yellow/ Green : Makes circuit when valve is closed

Maximum rating of microswitch at 12 or 24 volts = 2 amperes

OPERATION

When powered the solenoid holds the air intake shut down valve in the open (engine run) condition. On loss of power the spring within the shut down valve assembly moves the valve to the closed (engine stop) position, i.e. failure of power supply gives a fail safe (engine stopped) condition.

MAINTENANCE

WEEKLY:

Visually check the valve, solenoid and cable for damage or deterioration. Withdraw from service if significant damage or deterioration is observed.

MONTHLY:

Check that the fasteners locating the shut down valve and any associated intake system or support bracket fasteners are securely tightened.

Check that any flexible hoses in the engine intake between the SVX valve and engine are free from damage and suitable for further service.

Run engine, preferably at low idle. Use shut down control system emergency stop to close the intake shut down valve. The engine should stop within a few seconds. If not, check there are no leaks in the engine air intake system between the SVX valve and engine. If this does not resolve the problem remove the SVX valve to return to Chalwyn for investigation.



Chalwyn by AMOT

sales@chalwyn.co.uk
www.chalwyn.com

A division of Roper Industries Limited

UK

Western Way
Bury St Edmunds
Suffolk, IP33 3SZ
Tel: +44 (0)1284 715739
Fax: +44 (0)1284 715747

USA

8824 Fallbrook Drive
Houston
TX 77064
Tel: +1 (281) 940 1800
Fax: +1 (713) 559 9419

