

Diesel Engine Shutdown System

Models CSX-300, 310
CSX-301, 311

Typical applications

- Marine engine safety
- Petrochemical industry safety
- Vacuum trucks
- Cranes - both engines
- Land drilling rigs
- Offshore equipment outside defined hazardous zones
- Road vehicles and tankers
- Refinery equipment
- LNG plant equipment



Model CSX-300

Key features and benefits

- Automatic intake valve shut down on engine overspeed
- Built-in contact relay for direct connection to Chalwyn SVX valves
- Splash resistant IP66 metal enclosure
- Factory set voltage and high/low speed range inputs
- Cable glands included
- 12 volt (CSX-300) or 24 volt (CSX-310) systems available
- Powered by existing engine start battery
- Optional sensor circuit (in CSX-301 or CSX-311 versions) for shut down on low oil pressure and up to four temperature settings
- Can be tripped by gas detector added in series to normally closed sensor circuit
- Precision overspeed trip speed setting via simple press button without overspeeding engine
- Speed signal input from existing alternator or flywheel magnetic pickup
- Manual shutdown button available (optional)
- System status indication on manual shut-down button
- Meets Canadian regulations for safety near drilling rigs
- Meets US BOEMRE regulations for safety on offshore platforms

CHALWYN
by AMOT

Diesel Engine Shutdown System - Series 300

Description

Chalwyn Series 300 (12 volt) and Series 310 (24 volt) systems monitor engine speed to give an immediate engine shut down by closure of an air intake valve if engine overspeed is detected. Suitable for engine and vehicle applications not requiring full hazardous area compliant equipment.

The speed signal is taken from the existing engine alternator or flywheel magnetic pickup and is compared electronically with an easily programmed shut down setting. No calculations

or knowledge with respect to the drive ratio of the alternator or number of flywheel teeth is required. The system also includes an optional stop button to enable manual emergency closure of the intake shut down valve.

Optionally up to 5 preset sensors can be supplied as part of the system to additionally give shut down on high engine temperatures and/or low oil pressure. An automatic fuel shut down valve is also available if required.

Schematic Layout Series 301 and 311

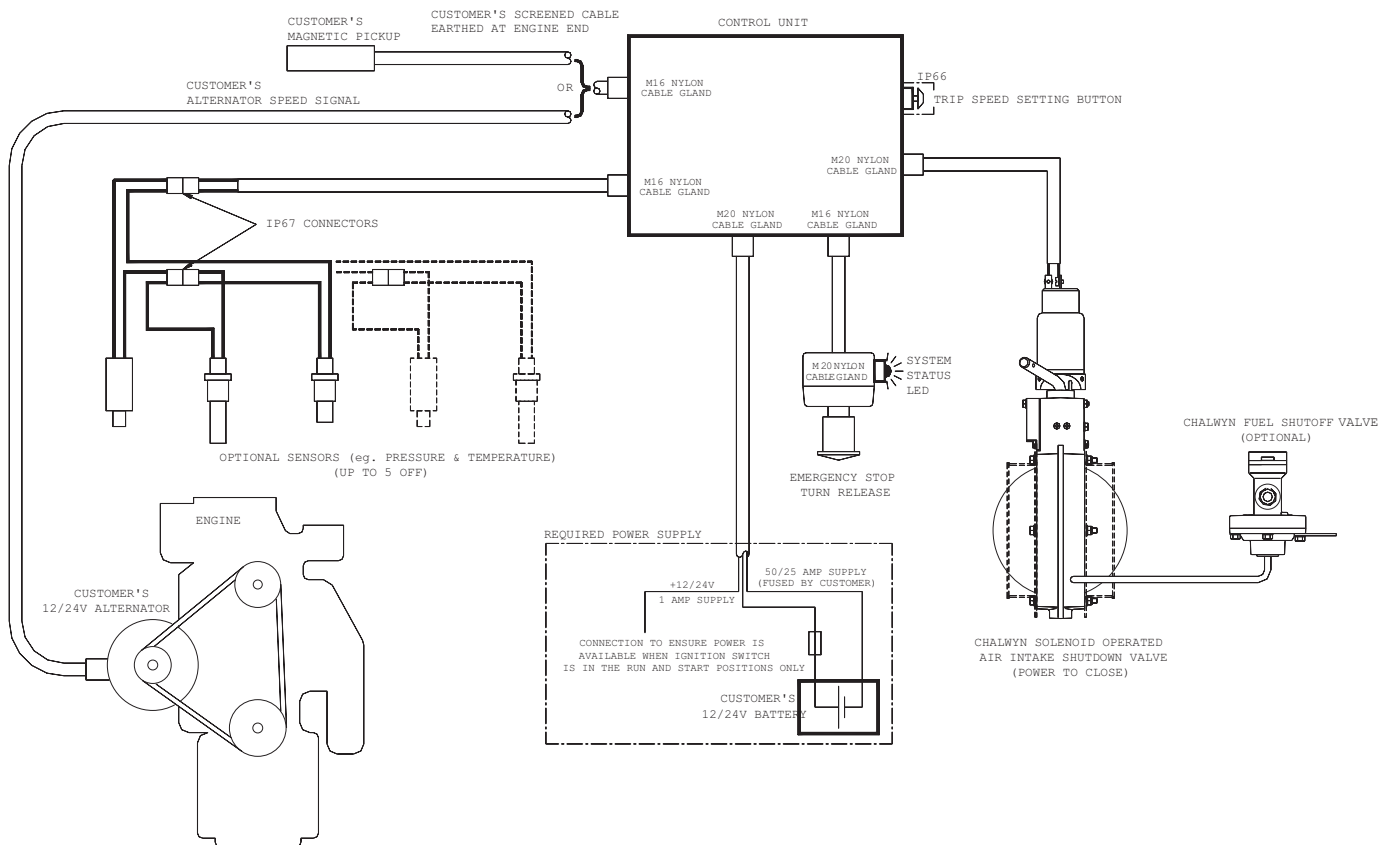

Diesel Engine Shutdown System - Series 300

Component Description

Chalwyn CSX-300 (12 volt) and CSX-310 (24 volt) Control Box

Die cast aluminium enclosure and lid complete with cable glands and meeting IP66. Contains the system micro-processor, associated electron-

ics and terminal block. The overspeed trip speed setting button is accessed by removal of a protective screw.

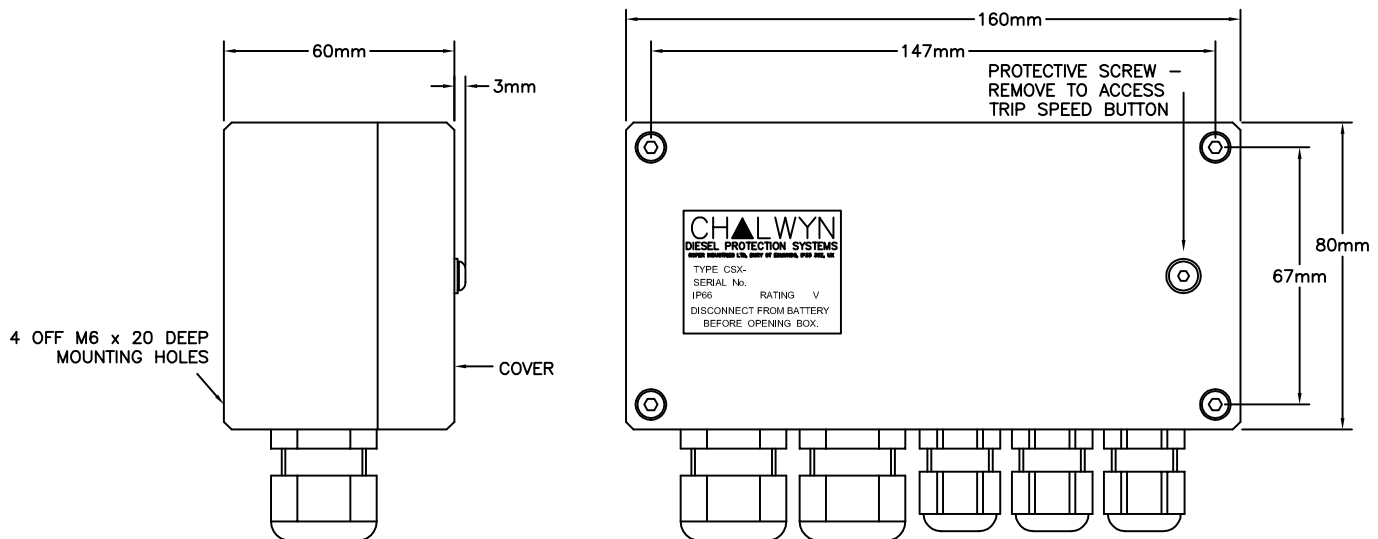

Inputs/Outputs:

- On/off signal via engine key switch circuit.
- Power from battery (via fuse)
- Speed signal from alternator or magnetic pick up
- Stop signal from emergency stop button.
- Run/stop signal from sensor circuit (where fitted)
- Power output to close intake shut down valve

Overspeed trip setting:

- 20% above engine speed at the time the trip speed setting button is operated

Number of sensors in circuit:

- No more than 5 connected in series

Time delay to establish oil pressure after engine start:

- 15 seconds, following detection of a speed signal, before sensor circuit is monitored. (No time delay for overspeed shut down function.)

Trip speed setting range:

- Maximum setting
 - 17500 rpm (alternator speed)
 - 10000 rpm (engine speed using magnetic pickup and 100 tooth flywheel)
- Minimum setting
 - 2400rpm (alternator speed)
 - 960rpm (engine speed using magnetic pickup and 100 tooth flywheel)
- Factory setting
 - 6000 rpm (alternator speed)
 - 2400 rpm (engine speed using magnetic pickup and 100 tooth flywheel)

Minimum speed at which system operates (not adjustable):

- 800 rpm (alternator speed)
- 320 rpm (engine speed using magnetic pickup and 100 tooth flywheel)

Diesel Engine Shutdown System - Series 300

Component Description continued

Chalwyn Air Intake Shut Down Valves (12 volt) SVX-381, SVX-581 & SVX-881 (and 24 volt) SVX-391, SVX-591 & SVX-891

Slim butterfly valves of various diameters. Manually latched open. Closed by powering the valve solenoid. Valve body and disc manufactured in corrosion resistant hard anodised alu-

minium with PTFE coating. Spindle and mechanism made from stainless steel. *Full details of this range of shut down valves are given in Chalwyn publication CE228.*

Emergency Stop Button Assembly CSX-840

Polycarbonate box incorporating the emergency stop button, system status light and cable entry gland. Degree of protection IP65.

This optional item is recommended to give clear indication of system status.

Chalwyn FSX-200 Automatic Fuel Shut Down Valve and Fitting Kit FKX-300 (requires 'Y' suffix added to SVX valve)

The FSX-200 is designed to automatically close down at the same time as the air intake shut down valve. A manual reset is fitted to the FSX-200. This only requires reset after an auto-

matic shut down or after a manual emergency shut down. *Full details of FSX-200 are given in Chalwyn publication CE226.*

Chalwyn Temperature Switches TSX-100, TSX-135, TSX-150 and TSX-200

Immersion type temperature switches with hermetically sealed electrically isolated cases. Designed for monitoring coolant and exhaust temperatures. Standard settings are 100°C, 135°C, 150°C and 200°C, normally closed.

Full details of the Temperature Switch range are given in Chalwyn publications CE304 and CE306.

Chalwyn Pressure Sensor PSX-010

Low oil pressure switch with electrically isolated body pre-set to 0.7 bar/10psi (falling), normally

open. *Full details of the PSX-010 are given in Chalwyn publication CE305.*

Selection

Select either the Series 300 or Series 310 to match the voltage used on the existing engine installation.

If required, identify and order optional sensors or optional fuel shut down valve as part of the total package.

Determine whether the speed signal will be obtained from the engine alternator (typically the 'W' terminal) or the flywheel magnetic pick-up. (The system will be configured at Chalwyn to suit the option selected.)

Select the size of the air intake shut down valve required and determine whether it is to be mounted between flanges or inserted in the air intake hose using one of the range of Chalwyn Air Inlet Hose Adaptors (see publication CE228). Ensure that, at the position selected to mount the intake valve, easy and safe access to the manual reset lever will be possible.

Important Notes:

The Series 300 and 310 systems will only give automatic shut down on engine overspeed, operation of the emergency stop button or, where fitted, sensor trip or break in the sensor circuit. Other fault conditions, which may cause loss of the protection provided by the Series 300/310 system, will not generally give an automatic shut down. Instead a warning will be indicated by the system status LED in CSX-840.

The Series 300 and 310 systems are not suitable for defined hazardous area applications.

For information on gas detectors that open the sensor circuit please contact Chalwyn.

Diesel Engine Shutdown System - Series 300

Installation (Mechanical)

Control Unit

Using the four M6 mounting holes in the base of the unit, mount the control unit to a sturdy plate using M6 x 20 fasteners. Ensure this mounting plate is supported and positioned to:

- a) Minimise vibration transmitted to the control unit.
- b) Give good access to the trip speed setting button without causing a hazard whilst the engine is running.
- c) Enable the electrical cables to be routed away clear of hot surfaces and moving parts.
- d) Ensure that the control unit is not subject to an effective ambient temperature exceeding 50°C (122°F).

Intake Shut Down Valve

1. In the case of a naturally aspirated engine, the Chalwyn SVX shut down valve should generally be fitted as close to the engine air intake manifold as possible. If an air intake flame trap is also fitted, the SVX must be installed upstream (air cleaner side) of the flame trap.
2. If the engine is turbocharged, fit the SVX downstream (engine side) of the turbocharger if space permits and the intake air temperature is less than 150°C (302°F) as usually found downstream of the intercooler. Any flame trap must be installed between the SVX and engine.
3. The SVX valve may be installed either horizontally or vertically.
4. Ensure that the SVX Valve is installed such that safe access to the reset lever is possible and the electrical cables can be routed away clear of hot, sharp or moving parts.
5. If hose adaptors are used, the mating hose should be of a reinforced type, provide adequate support for the valve and prevent excessive vibration. If necessary, additional support brackets mounted from the engine should be considered.
6. Particular care must be taken to ensure the integrity of the intake pipework between the SVX valve and intake manifold. Ideally metal pipework should be used and any gaps kept as short as possible, taking into account any relative movement, and closed by reinforced hose.
7. Any engine crankcase breather connections into the intake system between the SVX valve and engine, or any internal crankcase breather arrangement venting directly into the engine intake ports must be sealed and replaced by an external breather system venting either to atmosphere or to the intake system upstream of the shut down valve.

Emergency Stop Button Assembly

Use two M4 fasteners to mount the assembly via the two holes in the base. Ensure the assembly is mounted such that:

- a) The stop button is easily accessible
- b) The system status LED is always visible to the operator responsible for running the protected equipment.

Note: Disconnect the wires between stop button assembly box and cover when mounting the box.

Diesel Engine Shutdown System - Series 300

Optional Automatic Fuel Shut Down Valve

FSX-200 Fuel Shut Down Valve

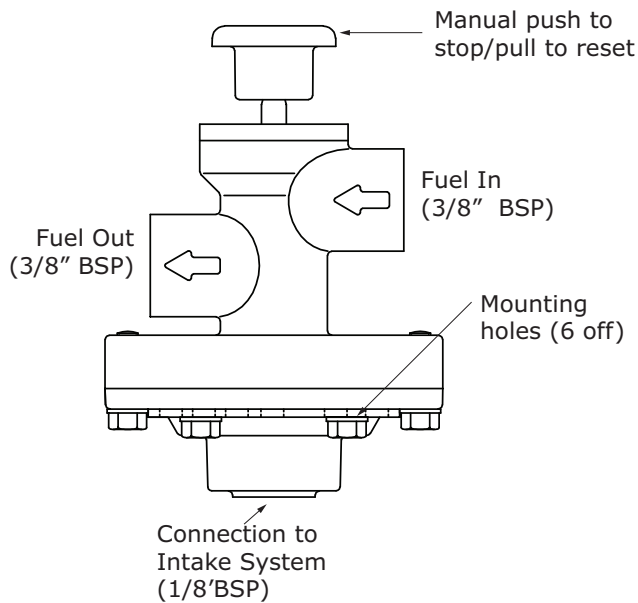

1. Install the FSX-200 into the fuel line as close as possible to the fuel injection pump. Support the FSX-200 using the mounting plate supplied.
2. Locate the two 1/8" BSP holes tapped through the SVX air shut down valve body. Using thread sealant or thread locking compound:
 - a) Tighten adaptor FKX-001 into the tapped hole on the engine side of the shut down valve disc.
 - b) Tighten blanking plug FKX-002 into the tapped hole on the body at air cleaner side of the SVX shut down valve disc.
3. Using the compression fittings and copper pipe supplied, connect the adaptor FKX-001 fitted in the air intake shut down valve to the fitting in the base of the FSX-200. Ensure all connections are leak free and that the copper pipe is suitably routed and clamped to avoid excessive vibration and/or damage.

Notes:

- a) After an automatic engine shut down or an emergency manual shut down via the Series 300 / Series 310, the FSX-200 reset lever (see diagram) must be pulled in before restart. It is not necessary to reset the FSX-200 after a normal fuel shut down is used to stop the engine.
- b) The fuel system pressure at the point of installation of the FSX-200 must not exceed 14 bar / 200 psi.

Optional Intrinsically Safe Sensors

Fit into the exhaust, coolant and oil pressure systems as appropriate. Ensure the leads are connected in series and can be routed to the CSX Control Unit via the IP67 connectors avoiding hot, moving or sharp objects.

Diesel Engine Shutdown System - Series 300

Installation (Electrical)

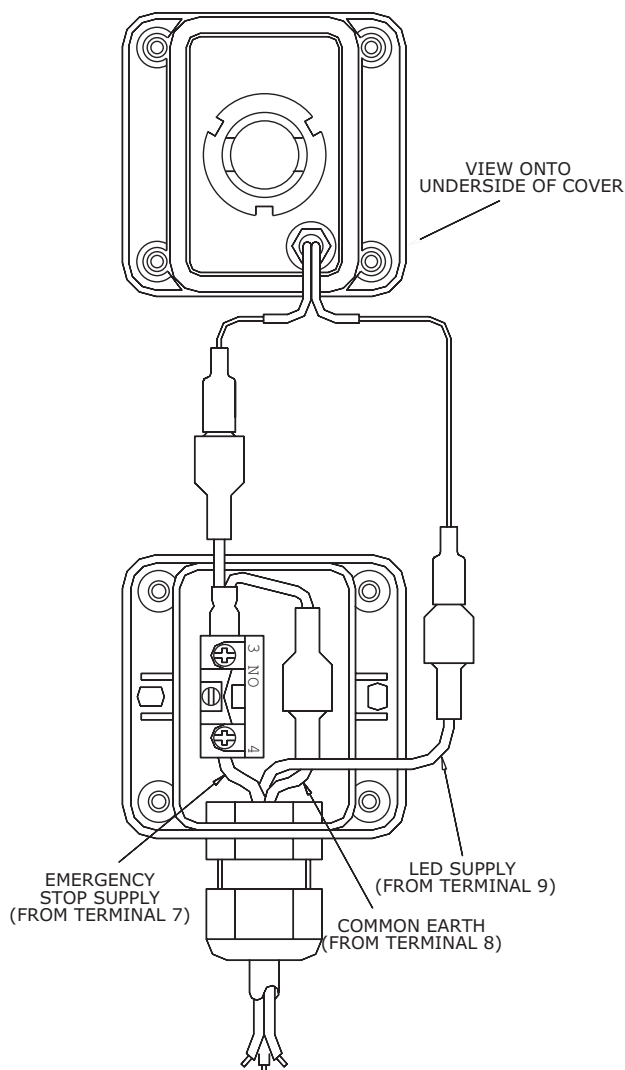
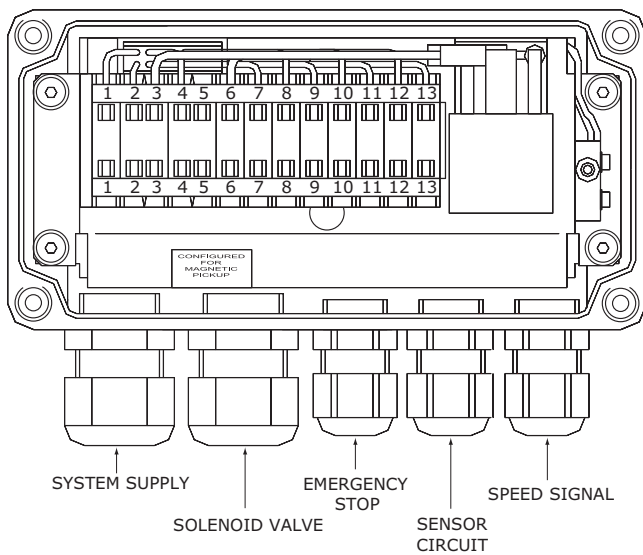

1. The diagram left shows the gland positions and terminal identifications for the CSX-301 and CSX-311 control units. The control unit is supplied with a blanking plug in place of the sensor circuit gland when a sensor circuit is not required (CSX-300 and CSX-310).
2. With reference to the wiring diagram over page, connect either the alternator speed signal or magnetic pick up speed signal to terminals 12 and 13 as appropriate having checked that the label inside the control unit confirms the correct configuration. A cable with outside diameter between 4.5 and 10mm is required to match the glands. Screened cable, earthed at the engine end, should be used for connecting a magnetic pick up.
3. If applicable connect up the sensor circuit using the IP67 connectors supplied. Use cable with outside diameter between 4.5 and 10mm.
4. Use 3 core cable with an outside diameter between 7 and 10mm to connect the emergency stop button assembly to terminals 7, 8 and 9 as shown here.
5. Connect the SVX air intake shut down valve to terminals 5 and 6 of the control unit. The cable must be specified to handle the pull current of 46 amps (12 volt applications) or 25 amps (24 volt applications) and have a outside diameter between 7 and 13mm. Note, the pull current is only applied for a period of less than 1 second when the valve is powered to close. The valve solenoid has an internal switch which reduces the current to the hold level of 1.1 amps (12 volt applications) or 0.5 amps (24 volt applications) immediately the valve reaches the closed condition. This reduces to zero once the Series 300/ Series 310 system is switched off.
6. Use three core cable of 7 to 13mm outside diameter and minimum core section of 2.5mm² to connect the on/off signal and the power supply to the control unit via terminals 1, 3 and 4. A 50 amp continuously rated fuse should be fitted in the power supply between battery and control unit. The on/off signal is to be controlled by the engine ignition switch such that the Chalwyn system is 'on' only when the ignition switch is in the engine 'start' and 'run' positions.

Diesel Engine Shutdown System - Series 300

Installation (Electrical) continued

Series 300 (12V) and Series 310 (24V) Wiring

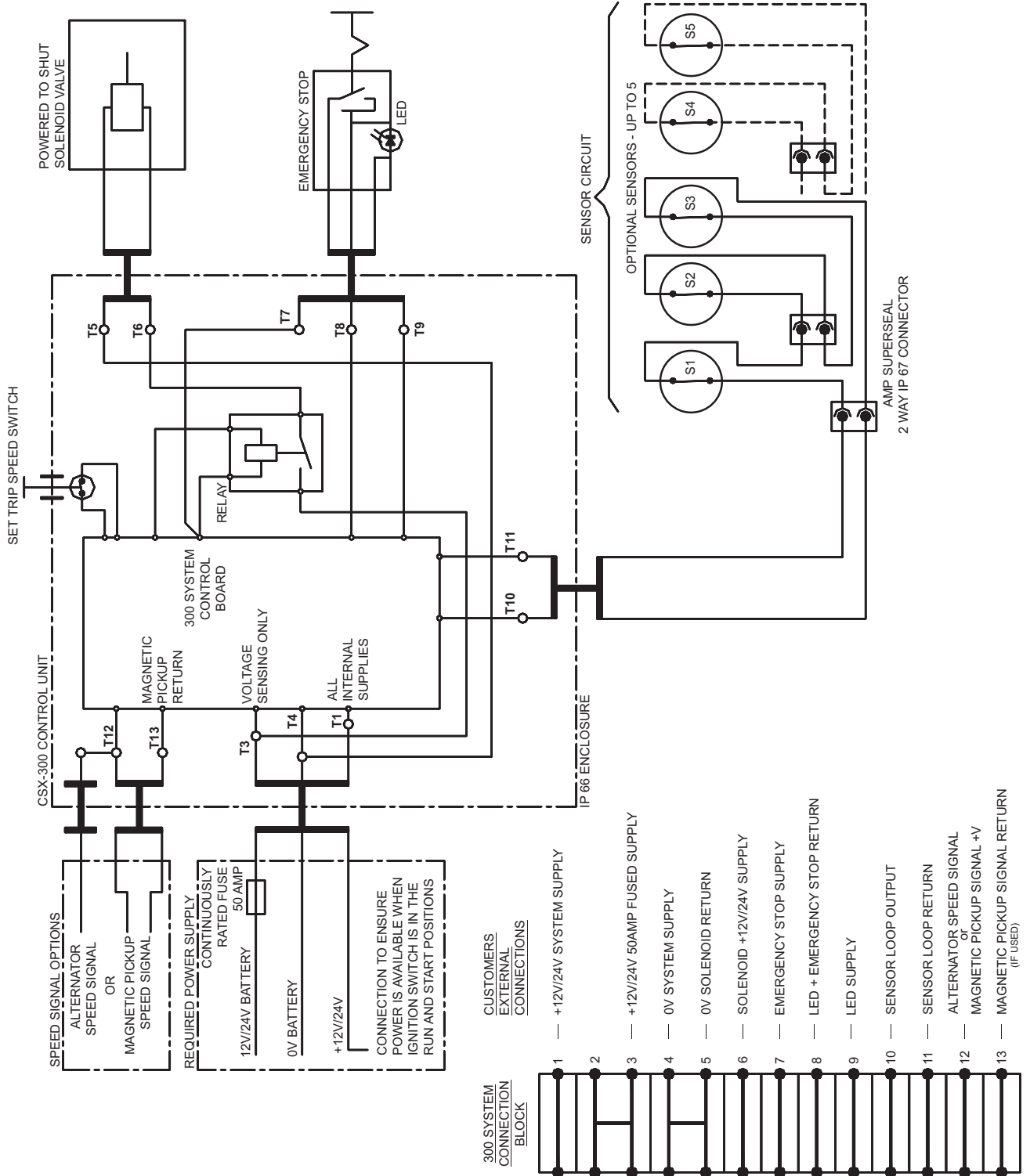

Diesel Engine Shutdown System - Series 300

Operation

1. On first start after installation the overspeed trip point must be set up as follows:

- a) Remove the protective screw from the control unit cover to expose the trip speed setting button.
- b) Check that the SVX air intake valve is latched open and, if fitted, the reset button of the fuel shut down valve is pulled up.
- c) Turn on the system by selecting the engine run position using the ignition switch. The Series 300/Series 310 system status LED should start to flash (100ms On / 2s Off).
- d) Start engine. The system status LED will switch to continuously on. If a sensor circuit is fitted, a time period of 15 seconds is allowed for the engine oil pressure to build up before the sensor circuit becomes active.

Note: If at any time during the following set up procedure a problem arises the engine may be stopped by normal fuel shut down using the ignition switch.

- e) Initially for checking purposes set the overspeed trip to a speed in the normal operating range of the engine by slowly increasing the engine to a mid range speed and then pressing and releasing the trip speed setting button. Note, while the trip speed button is held down the system status LED will change to fast flash (100ms On / 100ms Off) and then revert to continuously on once the trip speed button is released.
- f) Slowly increase the engine speed to check shut down occurs at exactly 20% above the speed at which the trip speed button was released. Following shut down the system status LED will change to the error flash signal (500ms On / 500ms Off). If an automatic fuel shut down valve is fitted, check that it has closed as indicated by the reset lever moving outwards to expose about 4mm of the lever.
- g) Once the engine has been shut down by the Series 300/Series 310 System it will not be possible to restart until the ignition switch has been operated to turn off and then turn on the system again.
- h) To check the operation of the fuel shut down valve, if fitted, reset the air intake valve but not the fuel shut down valve. Start engine. It should only run for a short period whilst consuming the residual fuel between the fuel shut down valve and the engine injectors.
- i) Using the same procedure as above, reset the overspeed trip point to the final value required in the field.

Notes:

To increase the trip speed setting from lower to a higher value, the trip speed setting button must be held in whilst accelerating from below the existing trip speed and released at the required higher value.

For many applications a suitable overspeed shut down will be 20% above the engine high idle (full throttle, zero load) speed.

- j) Refit protective screw to cover the trip speed setting button.
 - k) Re-start engine. Check operation of emergency stop button. Engine should stop immediately and the system status LED change from continuously on to the error flash signal.
 - l) If a sensor circuit is fitted, restart the engine, run for at least 15 seconds and then check operation by breaking the sensor circuit at any connector. The engine should shut down and the system status light change from continuously on to the error signal flash.
2. Once set up, normal engine start procedure is as follows:
- a) Following a normal shut down using the engine ignition key/fuel stop, carry out the standard start procedure for the engine. After start up check the Series 300/310 system status LED is continuously on. Note, if not continuously on, the Series 300/310 is not fully operational and MAY NOT BE GIVING ANY PROTECTION - see "Maintenance".
 - b) Following shut down of engine by the Series 300/310 system, including by operation of the emergency stop button, it will be necessary to turn off the Series 300/310 system using the ignition key. The air intake shut down valve and fuel shut down valve (if fitted) must then be reset before restarting followed by checking of the system status LED.
3. If at any time whilst the engine is running the system status LED starts to flash or is extinguished, this indicates that the Series 300/310 system may no longer be providing protection. Stop the engine at the earliest possible safe time to investigate.
4. Engine shut down
- a) Normal shut down. Always use the standard key switch/fuel stop.
 - b) Emergency shut down. Press emergency stop and operate key switch/fuel stop.

Diesel Engine Shutdown System - Series 300

Maintenance

System Status LED Codes

Continuously ON:

System operating normally with speed signal in range and sensor loop (if fitted) intact.

Flash 100ms ON / 100ms OFF:

Trip Speed Setting Button pressed.

Flash 100ms ON / 2s OFF:

Speed signal not present or below minimum value.

Flash 500ms ON / 500ms OFF:

System has tripped or internal control system error detected or main power supply not present

No Light:

System not turned on, wiring fault or system fault.

Routine Maintenance

Carry out the following maintenance schedule.

Any problems identified must be rectified prior to returning the equipment to service.

After each start:

After start up check that the system status LED is continuously on.

Weekly:

After starting engine press emergency stop button whilst running at low rpm. Check engine stops within a few seconds. Check that both the

air intake valve and fuel shut down valve (if fitted) require reset.

Monthly:

Check that fasteners locating the air intake valve and any associated intake system or support brackets are tight.

Ensure that all electrical cables are properly supported and free from damage.

Check that any flexible pipework between the air intake shut down valve and engine is free from damage and suitable for further service.

Check that the fuel shut down valve and associated pipework is leak free and suitably supported.

Yearly:

Remove covers from the control unit and the emergency stop button assembly to enable an internal inspection. Check that all visible wiring is in a serviceable condition and connections are tight.

cover and spring but do not remove the centre nut retaining the diaphragm. Check diaphragm is in serviceable condition. Carefully clean the diaphragm cover and the orifice to the pipe connection. Refit spring and cover.

Check there is no sign of significant dust or moisture ingress and that the cover seals are intact. Refit covers.

Check operation of sensor circuit and fuel shut down valve (if fitted) as described under "Operation".

If applicable remove pressure and temperature sensors. Check operation and calibration. Refit.

Remove the 6 off M5 screws and washers retaining the diaphragm cover of the FSX-200 fuel shut down valve (if fitted). Carefully remove the

Diesel Engine Shutdown System - Series 300

Control System Information

CHALWYN
by AMOT
Diesel Engine Safety Solutions

System Selection Guide

Diesel Engines: A potential source of ignition

Diesel engine speed is governed by controlling the amount of fuel fed to the engine through the fuel system and internal speed governor. If a fermentable material is drawn into the air intake system of a diesel engine it acts as an additional unregulated fuel supply. This additional fuel source can cause the diesel engine to accelerate or overspeed out of control. This condition is referred to as diesel engine runaway. The result of a diesel engine runaway can range from engine damage to catastrophic explosion.

Turning off the normal shutdown system will only turn off the engine's normal fuel source. Once the fermentable material is being drawn into the engine intake it may not be possible to stop the engine using the normal engine shutdown. The most effective way of shutting down a runaway diesel engine is with an air intake shut-off valve. An air intake shut-off system completely isolates the engine intake system, cutting off both the external fuel source and the air required to keep the engine running.

Below are a few industries that operate diesel engines in areas where combustible gas, vapour, or dust can exist:

- Oil & Gas
- Mineral
- Mining
- Marine
- Airports
- Power Generation
- Transportation
- Fire Control
- Drilling
- Agriculture

Chalwyn has supplied Diesel Engine Overspeed Safety Shutdown solutions for hundreds of applications. A few example applications are listed below:

- Drilling rigs (onshore & offshore)
- Drilling support equipment
- Well servicing equipment
- Railway support equipment
- Bulk haulers and road tankers
- Underground mining equipment
- Construction equipment
- Front end trucks
- Generator sets
- Air compressors
- Emergency response vehicles
- Aircraft refuelling tankers
- Welding sets
- Work boats and barges
- Hydraulic power packs
- Light towers
- Water pumps
- Front end (hydraulic fracturing) trucks
- Vacuum trucks
- Cranes

Product Overview

Butterfly Air Intake Shutoff Valves

The Butterfly Air Intake Shutoff Valve provides emergency shutdown of a diesel engine. When the positive spring-actuated valve closes, it isolates the diesel engine of air and combustible vapor ingested through the air intake line.

- Compact design
- Three body sizes:
 - 2", 3", 4"
 - Large range of modular hose adaptors between 1 1/2" and 3"
 - Step change of diameter possible
 - Electric SVX range in 12 or 24 VDC
 - Manual reset by lever on valve
 - Position indicator switch available
 - Pneumatic MPX range (Manual reset)
 - Pneumatic PVX range (Automatic reset)
- Manual 100% emissions (Manual reset)
- Ventures with combinations of features
- Designed for 40°C to 150°C (104°F to 302°F) intake air
- Major components manufactured of aluminum, brass, and stainless steel
- Corrosion resistant body components
- Zinc body versions for Group 1 or mining available
- Manufactured in the United Kingdom

For specific dimensions, view technical brochures at www.dieselsafety.com/technical-downloads

Overspeed Switches

Chalwyn offers two speed switches to complete the automatic safety system:

- Reversible Speed Switch**
 - Single and dual support versions available (ROR-15 or ROR-25)
 - Operates on 12 VDC or 24VDC systems
 - LED trip indicator
 - Built in 25 of RPM test button to simulate overspeed condition
 - Easily installed using standard connections
 - Optional lightweight Polymer enclosure available
 - Optional ROP-100 Free Push available for 200 onwards Ford and Bosch alternators
- CSX-300 Range Speed Switch**
 - Includes 50 AMP contact relay built in
 - Splash resistant IP66 metal enclosure
 - Optional sensor detection circuit
 - Single push button speed setting
 - Factory set voltage and high/low speed inputs (specify when ordering)
 - Cable glands included
- CSX-500 Reverse Push Stop Button**
 - Compatible with CSX-300 range
 - System status LED indicator
 - Splash resistant Polymer casing

For systems that must operate in ATEX defined hazardous areas (Zone 2) please see 'Shutdown Systems - Diesel' at www.dieselsafety.com

Further information on the wide range of Chalwyn automatic overspeed shutdown systems can be found at www.dieselsafety.com/technicaldownloads.

For hazardous area automatic diesel engine shut down systems see Chalwyn Series 110, 111 and 210 Systems - Chalwyn Publication Nos. CE233 and CE234.



Chalwyn by AMOT

sales@chalwyn.co.uk
www.dieselsafety.com

A division of Roper Industries
Limited

UK

Western Way
Bury St Edmunds
Suffolk, IP33 3SZ
Tel: +44 (0)1284 715739
Fax: +44 (0)1284 715747

USA

8824 Fallbrook Drive
Houston
TX 77064
Tel: +1 281 940 1800
Fax: +1 713 559 9419

Canada

3230 97 Street
Edmonton
Alberta, T6N 1K4
Tel: +1 780 465 4429
Fax: +1 780 469 6275

